

VIBRATION-DAMPED AIR HAMMER

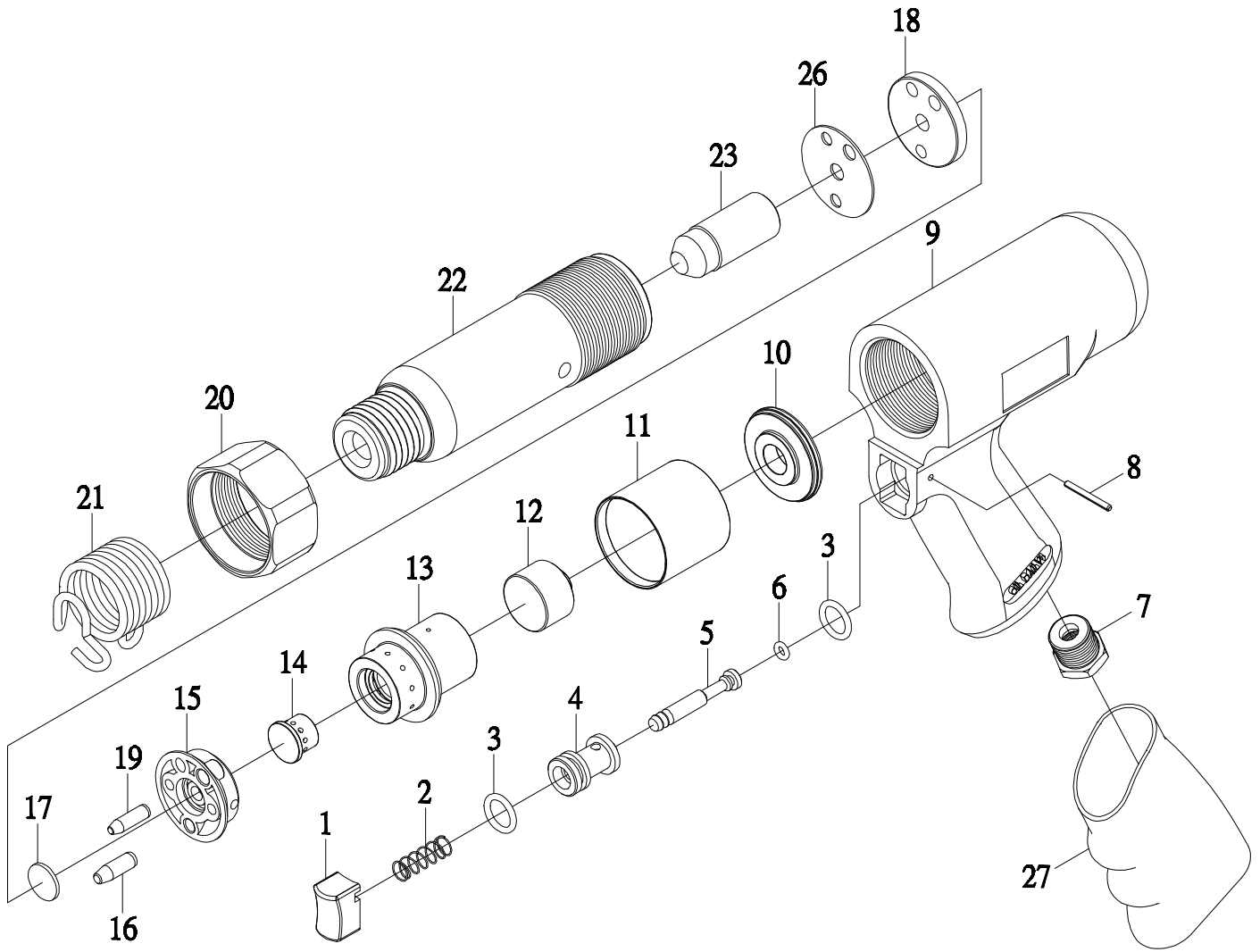

SPECIFICATION:			
*BLOW PER MINUTE	3000 BPM	*PISTON SIZE	19
*AIR CONS	10 CFM	*WEIGHT	2 KG
*AIR PRESSURE	90 PSI	*AIR INLET	1/4"PT(NPT)
*HOSE SIZE	3/8"ID		

REF. NO.	PART NO.	DESCRIPTION	Q'TY	REF. NO.	PART NO.	DESCRIPTION	Q'TY
1	810001	VALVE BUTTON	1	15	810015	UPPER VALVE SEAT	1
2	810002	VALVE SPRING	1	16	810016	DOWEL PIN (L)	1
3	810003	"O" RING (d11.8×W2.4) (P12)	2	17	810017	VALVE DISC	1
4	810004	VALVE BUSHING	1	18	810018	LOWER VALVE SEAT	1
5	810005	THROTTLE VALVE STEM	1	19	810019	DOWEL PIN (S)	1
6	810006	"O" RING (d3.8×W1.9) (P4)	1	20	810020	EXHAUST DEFLECTOR	1
7	810007	AIR INLET BUSHING	1	21	810021	SPRING RETRAINER	1
8	810008	SPRING PIN (∅2.5×24L)	1			CYLINDER BARREL-ROUND	1
9	810009	HANDLE	1	22	810022	CYLINDER BARREL-HEX (10mm)	1
10	810010	VALVE SEAT (AIR CUSHUION ASSY)	1			CYLINDER BARREL-HEX (11mm)	1
11	810011	INNER CYLINDER (AIR CUSHUION ASSY)	1	23	810023	PISTON	1
12	810012	INNER PISTON (AIR CUSHUION ASSY)	1	26	810026	IRON SPACER	1
13	810013	VALVE HEAD (AIR CUSHUION ASSY)	1	27	810027	GRIP	1
14	810014	VALVE CAP	1				